



**Renew the air,
prevent mold
and save energy!**

ASPIRVELO AIR ECOCOMFORT

The most complete range
of single-room HRU

FantiniCosmi
Industrie

DAMP

MOLD

SMELLS

EXHAUST AIR



ASPIRVELO AIR ECOCOMFORT

Prevent unwanted mold and damp saving money on your heating and A/C expenses

How does it work?

ECOCOMFORT is a de-centralized high efficiency heat recovery unit that ensures permanent ventilation of the dwelling with up to 90% efficiency.

Thanks to the continuous ventilation molds and damp can be prevented ensuring a good air quality.

Ecocomfort is equipped with DC brushless motor with reverse ventilating cycle to ensure a continuous air change. The intake air is filtered by a G3 filter easy to clean and to access for cleaning. Thanks to the ceramic heat exchanger the heat of the extracted air flowing through it is accumulated and transferred to the intake air when the flow is reversed.

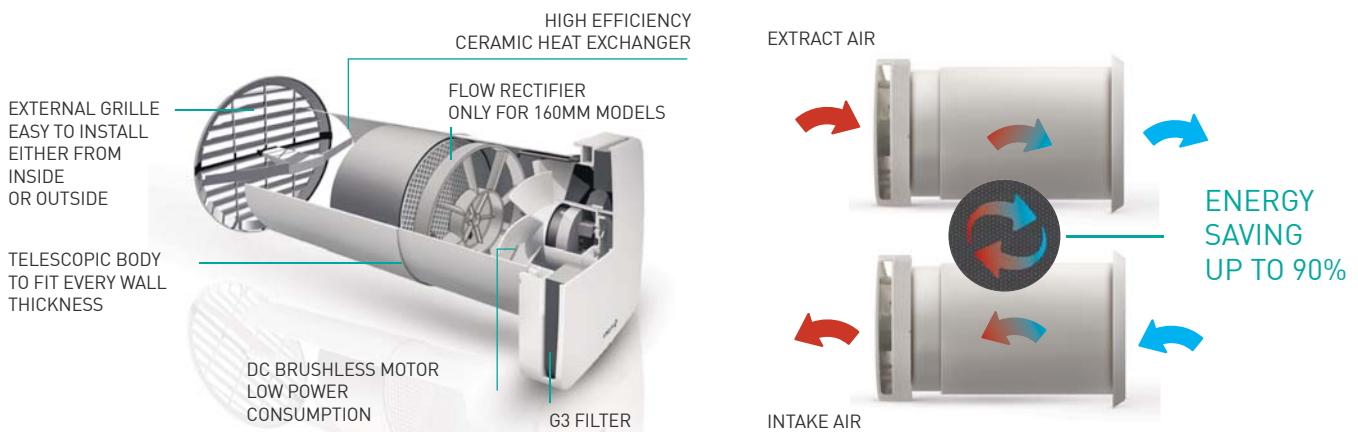

FRESH AIR

COMFORT

ENERGY SAVING

RF controlled or wired with wall mounting control box

ECOCOMFORT is available in 2 versions: RF remote control suitable to manage up to 64 units and wired with wired wall mounting control unit to manage up to 4 units.



Ø 160 and 100 mm

ECOCOMFORT serie is available to fit 2 duct sizes: 100 mm suitable for rooms up to 22 sqm and 160 mm for rooms up to 50 sqm. In one system both models can be installed to fit the room size. 160 mm version is equipped with a flow rectifier to grant higher performances.



Confort in any condition

ECOCOMFORT RF is equipped with temperature, humidity and brightness sensors to adjust the fan speed according to the ambient conditions. NIGHT Mode detects automatically the light level in the room to reduce the fan speed during the night.



Single room or multi room? Both!

ECOCOMFORT is a flexible product to suit every installation. It can be used for 1 room ventilation or connecting several units among the 2 available diametres to build a multi-room ventilation system.

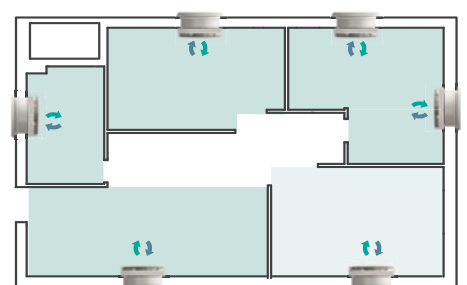

Easy to install

ASPIRVELO AIR Ecocomfort must be installed on the external walls. Thanks to the telescopic body it fits easily every wall thickness between 24 and 58 cm. The external grille can be easily installed from outside or inside without the need of any scaffolding.

EXTERNAL GRILLE EASY TO INSTALL EITHER FROM INSIDE OR OUTSIDE

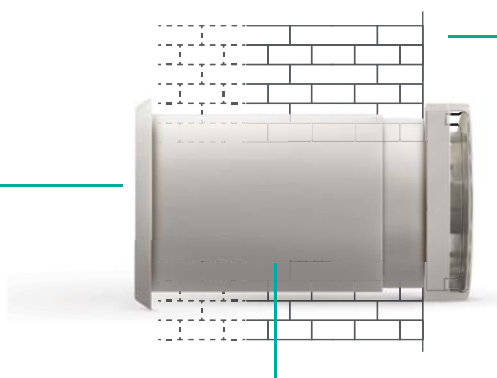

INSTALLATION ON EXTERIOR WALL

TELESCOPIC ADAPTER TO SUIT DIFFERENT WALL THICKNESS
MINIMUM LENGTH 24 CM, MAXIMUM LENGTH 58 CM

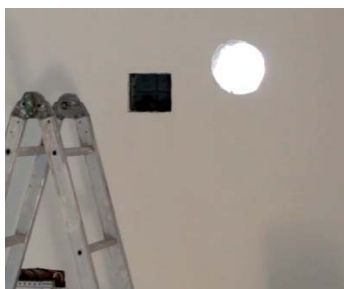

1

Drill a hole in the external wall



2

Insert the telescopic tube with the desired length



3

Insert the external grille



4

Insert the ceramic heat exchanger



5

Fix the fan to the wall and make the proper electrical connection



6

Fasten the front cover

A complete range to suit every need

RF REMOTE CONTROL



ASPIRVELO AIR ECOCOMFORT 100 RF - ECOCOMFORT 160 RF series

ECOCOMFORT RF is an high efficiency decentralized heat recovery unit with RF remote control.

The minimum configuration is the "Master" unit with the remote control to which up to 64 slave units can be added.

The remote control, thanks to its intuitive graphics, allows the user to set and modify the desired operating mode and to verify the setting status.

Thanks to the temperature, humidity and brightness sensors, ECOCOMFORT RF adjusts the fan speed according the ambient conditions ensuring the ideal comfort.

"MASTER" heat recovery unit includes: heat recovery unit, telescopic body, grille and RF remote control

Secondary heat recovery unit includes: heat recovery unit, telescopic body, grille



MANUAL MODE SETTING:
air intake, air extraction and alternate air intake / extraction



AUTOMATIC MODE SETTING:
The master ventilating unit regulates automatically adjusts air intake / extract cycles and the fan speed according to the room / ambient conditions according to temperature, humidity and light brightness readings

230V Remote control
IP40 Heat recovery unit
IPX4
A

Complies with Reg. (UE) 1254/2014



3 SPEEDS:
low, medium and high fan speed



NIGHT MODE
minimum fan speed



OFF KEY SYSTEM



SYSTEM STATUS REQUEST
set mode and fan speed



WALL CONTROL UNIT



ASPIRVELO AIR ECOCOMFORT 100 - ECOCOMFORT 160 series

ECOCOMFORT is an high efficiency decentralized heat recovery unit with a mechanical wall mounting control unit

The control unit can be mounted on the wall or on a 3-module flush mounting box to control the fan speed, intake or extraction cycle of up to 4 units. The knob allows to change the intake / extraction cycle according to the outdoor climate conditions.

“MASTER” heat recovery unit includes: heat recovery unit with grille, telescopic body, control unit and 12Vdc feeder

Secondary heat recovery unit includes: heat recovery unit, telescopic body, grille

230V

IP20

IPX4

A

Control unit Heat recovery unit

Complies with Reg. (UE) 1254/2014

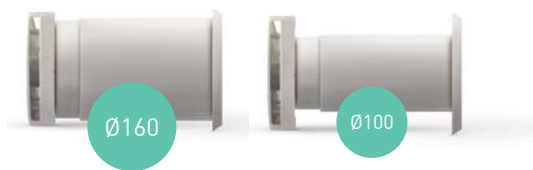

2 SPEED:
high, low and off fan speed

IN AUTO OUT

MANUAL AND AUTOMATIC MODE SETTING
air supply, air extraction and alternate cycle







SEASON SETTING:
the unit alternate cycle according to the season or user needs

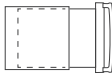

CHOOSE YOUR MODELS

MASTER

CODE	MODEL	Ø	SQM	speed	m³/h	W	dB(A) 1,5 mt				
AP19981	ECOCOMFORT 160 RF	160 mm	50 smq	low	28	2,0	27	•	•	•	•
				medium	48	3,8	32				
				high	68	6,6	38				
				sleep	15	nd	nd				
AP19987	ECOCOMFORT 100 RF	100 mm	22 smq	low	8	2,0	18	•	•	•	•
				medium	18	3,8	23				
				high	30	6,6	28				
				sleep	4	nd	nd				
AP19980	ECOCOMFORT 160	160 mm	44 smq	low	38	2,0	28	•	•	•	•
				high	60	4,0	34				
AP19984	ECOCOMFORT 100	100 mm	20 smq	low	12	1,5	21	•	•	•	•
				high	25	2,0	24				

SLAVE UNITS

AP19982	ECOCOMFORT SAT 160 RF	160 mm	50 smq	low	28	2,0	27	•	•	•	•
				medium	48	3,8	32				
				high	68	6,6	38				
				sleep	15	nd	nd				
AP19988	ECOCOMFORT SAT 100 RF	100 mm	22 smq	low	8	2,0	18	•	•	•	•
				medium	18	3,8	23				
				high	30	6,6	28				
				sleep	4	nd	nd				
AP19979	ECOCOMFORT SAT 160	160 mm	44 smq	low	38	2,0	28	•	•	•	•
				high	60	4,0	34				
AP19985	ECOCOMFORT SAT 100	100 mm	20 smq	low	12	1,5	21	•	•	•	•
				high	25	2,0	24				

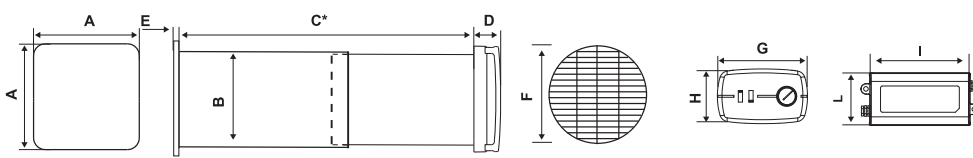

MODEL	A	B	C	D	E	F	G	H	I	L
ECOCOMFORT 160		160	530				140	85	140	85
ECOCOMFORT SAT 160	180			47	20	190	-	-	-	-
ECOCOMFORT 100		107	570				140	85	140	85
ECOCOMFORT SAT 100							-	-	-	-

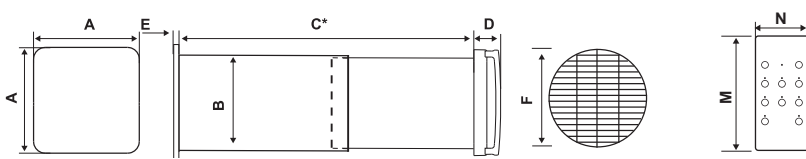

MODEL	A	B	C	D	E	F	M	N
ECOCOMFORT 160 RF		160	530				125	60
ECOCOMFORT SAT 160 RF	180			47	20	190	-	-
ECOCOMFORT 100 RF		107	570				125	60
ECOCOMFORT SAT 100 RF							-	-

ACCESSORIES

AP19986	KIT COMMISSIONING PHASE FOR Ø160	Useful kit during the commissioning phase in order to install the fan separately from the electrical / wall part. The KIT includes: telescopic body, external grille and outlet cover.
AP19978	SPARE FILTER FR004	all ECOCOMFORT models



FANTINI COSMI SPA Via dell'Osio, 6 - 20090 Caleppio di Settala MI, Italy
Ph. +39 02 956821 | Fax +39 02 95307006 | info@fantinicosmi.it

EXPORT DEPARTMENT Ph +39 02 95682229
export@fantinicosmi.it

www.aspira.com